



*ELECTRIC VEHICLES*



Owner's Manual and Service Guide

**Magellan:  
Magellan 2-AC, Magellan 2+2-AC,  
Magellan 4-AC and Magellan 4+2-AC**

Thanks for buying the Star EV Magellan. This manual contains information you will need for proper operation, maintenance, and care of your Magellan. A thorough understanding of these simple instructions will help you to obtain maximum enjoyment from your new Star EV.

If you have any questions about the operation or maintenance of your Magellan, please consult your Star EV dealer.

Read and understand this manual completely before operating your Star EV.

This manual should be considered a permanent part of your Magellan and should remain with the car when lending or resold.

# Table of Contents

|                               |           |
|-------------------------------|-----------|
| <b>Vehicle Specifications</b> | <b>4</b>  |
| <b>Operator Safety</b>        |           |
| Safety Precautions            | <b>5</b>  |
| Safety Considerations         | <b>6</b>  |
| Driver Qualifications         | <b>6</b>  |
| Golf Course Safety            | <b>7</b>  |
| Maintenance for Safety        | <b>8</b>  |
| <b>Controls</b>               | <b>8</b>  |
| <b>Pre-Operation Check</b>    |           |
| Checklist                     | <b>12</b> |
| Operation                     | <b>13</b> |
| <b>Storage</b>                | <b>13</b> |
| <b>Maintenance</b>            |           |
| Periodic Maintenance Chart    | <b>14</b> |
| Battery Care                  | <b>15</b> |
| <b>Electrical Diagrams</b>    | <b>18</b> |

# 1: Vehicle Specifications

| <b>Magellan</b> Magellan 2-AC, Magellan 2+2-AC, Magellan 4-AC, and Magellan 4+2-AC |   |                         |  |
|--|---|-------------------------|--|
| <i>Passengers</i>  | 2, 4, or 6 (2 facing backward on 2+2 and 4+2)   | <i>Brake System</i>     | Four-wheel hydraulic disc with electronic mechanical parking brake               |
| <i>Battery System</i>  | Eight 6 V (48 V) batteries, Trojan T-105  | <i>Body Material</i>    | Plastic  |
| <i>Motor Power</i>   | 2 and 2+2: 6 hp AC motor<br>4 and 4+2: 7 hp   | <i>Controller Power</i> | 2 and 2+2: 275 A Curtis AC controller / 4 and 4+2: 350 A Curtis AC controller    |
| <i>Top Speed</i>   | 19.5 mph (20-25 mph if street legal)  | <i>Front Suspension</i> | Independent A-arm with coil over shocks  |
| <i>Load Capacity</i>   | 2 and 2+2: 800 lbs / 4 and 4+2: 1,000 lbs   | <i>Rear Suspension</i>  | Leaf spring and shock  |
| <i>Weight w/ Batteries</i>   | 2+2: 1315 lbs / 4+2: 1500 lbs   | <i>Tire Size</i>        | 205/50/10 CST DOT tire   |
| <i>Dimensions</i>  | 2: 94" x 46" x 74" (L x W x H)<br>2+2: 115" x 47" x 75" (L x W x H)<br>4: 126" x 47" x 75" (L x W x H)<br>4+2: 146" L x 47" W x 75" H (L x W x H) | <i>Tire Pressure</i>    | 30 psi   |
|  |   | <i>Steering System</i>  | Rack and pinion  |
| <i>Ground Clearance</i>  | 5.5"  | <i>Roof</i>             | Plastic, color-matched   |
| <i>Turning Radius</i>  | 2 and 2+2: 11 ft / 4 and 4+2: 15 ft   | <i>Windshield</i>       | Foldable, tinted   |
| <i>Wheel Type</i>  | 10" machined aluminum   | <i>Drive Train</i>      | Direct rear drive with 16:1 ratio  |
| <i>Wheel Base</i>  | 2 and 2+2: 68" / 4 and 4+2: 97"   | <i>Voltage Reducer</i>  | 20 A, 48 V to 12 V reducer included  |
| <i>Top Climbing Grade</i>  | 30%   | <i>Warranty</i>         | Four year limited warranty, two year bumper-to-bumper warranty (less wear items) |

## 2: Operator Safety

Read and understand this manual completely before operating your golf car. Failure to follow WARNING instructions could result in severe injury or death to the golf car occupants, a bystander, or a person inspecting or repairing the golf car.

Particularly important information is distinguished in this manual by the following notations: the safety alert symbols, warnings, cautions, and notes. Please read the following labels carefully before operating your golf car, and promptly replace any labels which become damaged or removed.

Star EV golf cars are designed to be simple to operate. However, be sure to observe the following:

- Read this Owner's/Operator's manual and all safety and instruction labels on the golf car before operating.
- Do not allow more than one occupants per seat. The different vehicles are restricted to different numbers of occupants unless equipped with a rear seat.
- Do not operate the golf car while under the influence of alcohol or drugs; their affect on vision and judgment makes operating a golf car dangerous.
- Do not operate the golf car on public streets, roads, or highways unless allowed by law or local regulating authority.
- Keep your entire body inside the golf car, remain seated, and hold on when the car is in motion.
- Do not start the golf car until all occupants are seated.
- Keep your hands on the steering wheel and your eyes on the path ahead.
- Use extra care in congested areas or when backing up. Always back up slowly, and watch carefully. Avoid starting or stopping abruptly. Vary the speed of the golf car to match the terrain of the course. Avoid turning the steering wheel too sharply at higher speeds. Always drive slowly straight up or straight down slopes and never at an angle.
- Do not make any modification or addition which affects capacity or safe operation, or make any changes not in accordance with the owner's operator's manual.
- **WARNING:** Explosive gases are released when batteries are charged or discharged. Keep well ventilated. Keep sparks, flames and cigarettes away from batteries. Shield eyes when working near batteries.
- Star EV golf cars do not protect passengers from storms. When driving in a rainstorm, passengers should leave the car and take shelter in safe areas.

## ***Safety Precautions during Maintenance***

When performing maintenance, follow all safety instructions contained in the manufacturer's operation and service manuals, as well as the following safety procedures:

- Properly immobilize golf car before beginning any maintenance. Properly block chassis before working underneath golf car.
- Avoid fire hazards, and have appropriate fire protection equipment available.
- Before working on an electric golf car, disable the car's electrical system in accordance with the manufacturer's instructions. (Before disconnecting the batteries, push the button "Tow/Run" to "Tow" side. If not, a battery

explosion could occur.)

- Use only properly insulated tools when working on electrically powered golf cars and around batteries.
- Maintain all safety devices including brakes, steering mechanisms, and warning devices in a safe operating condition. Do not modify these safety devices as supplied by the manufacturer.
- After each maintenance or repair, the car must be driven by a qualified, trained, and authorized person – in an area free of pedestrian traffic – to ensure proper operation and adjustment.
- Record all maintenance performed in a maintenance record log by date, name of person performing maintenance, and type of maintenance. Periodically inspect maintenance log to ensure accurate and complete entries.
- Provide operator comment cards to assist in identifying non-periodic maintenance needs for specific golf cars.
- Maintain in a legible condition all nameplates, warnings, and instructions provided by the manufacturer. If new nameplates, warnings, or instructions are needed, contact your Star EV dealer.

## ***Safety Considerations***

Like all machines, golf cars can cause injury if improperly used or maintained. This section contains broad safety practices required for safe golf car operation.

Before golf cars are operated, golf course personnel should establish any additional safety practices that may be required for safe operation.

The information contained here is intended for golf course personnel responsible for golf car safety. If you are responsible for the operation and maintenance of this golf car, we encourage you to implement this golf car safety program.

## ***Driver Qualifications***

Allow only authorized people to operate golf cars. It is recommended that only people who possess a valid motor vehicle driver's license be allowed to operate golf cars.

Place operation and safety instructions recommended by the golf car manufactur-

er, along with the golf course safety rules, in a conspicuous place near the golf car rental area or golf car pick-up area. It is also recommended that the following warning be posted in a conspicuous location.

## ***Golf Course Safety***

Perform safety surveys regularly to identify hazardous areas where golf cars should not be operated.

The following golf course hazards must be made safe:

- *Steep Grades:* Where steep grades exist, restrict golf cars to designated golf car pathways where possible. In addition, identify steep grades with a suitable warning like: WARNING: Steep Grade, Descend Slowly With Foot On Brake Sharp Turns, Blind Corners, Bridge Approaches. Chain or rope off these potentially hazardous areas or identify them with a suitable warning describing the nature of the hazard and the proper precautions to be taken to avoid the hazard.
- *Wet Areas:* Wet grass may cause a golf car to lose traction and may affect stability. Reduce speed in wet areas or during periods of inclement weather.
- *Loose Terrain:* Loose terrain may cause a golf car to lose traction and may affect stability. Repair loose terrain, chain or rope off these areas, or identify loose terrain with a suitable warning.
- *Golf Car and Pedestrian Interference:* Reroute golf car traffic or pedestrian traffic in congested areas wherever possible to prevent accidents. If it is impractical to reroute traffic, erect warning signs to warn pedestrians of golf car traffic, and to warn golf car operators to drive slowly, use caution, and watch for pedestrians.
- *Ventilation:* Properly ventilate all maintenance and storage areas in accordance with applicable fire codes and ordinances to avoid fire hazards. Ventilation is required to remove hydrogen gas from the car storage areas during the battery charging process.

For electric powered golf cars, the amount of hydrogen gas emitted during charging depends on a number of factors, such as the condition of the batteries, the output rate of the battery charger, and the amount of time the batteries are on charge. Because of the highly volatile nature of hydrogen gas and its propensity to rise and accumulate at the ceiling in pockets, a minimum of five air changes per hour is recommended. Consult applicable fire and safety codes for the specific ventilation

levels requirement, as well as requirements for the use of explosion proof electrical apparatus.

## ***Maintenance required for Golf Car Safety***

*Preventative Maintenance:* Perform all scheduled maintenance in accordance with manufacturer's recommendations to provide the golfing patron with a safe, properly operating golf car.

*Personnel:* Allow only qualified, trained, and authorized personnel to inspect, adjust, and maintain golf cars.

*Parts and Materials:* Use only replacement parts and materials recommended by the manufacturer.

## 2: Controls

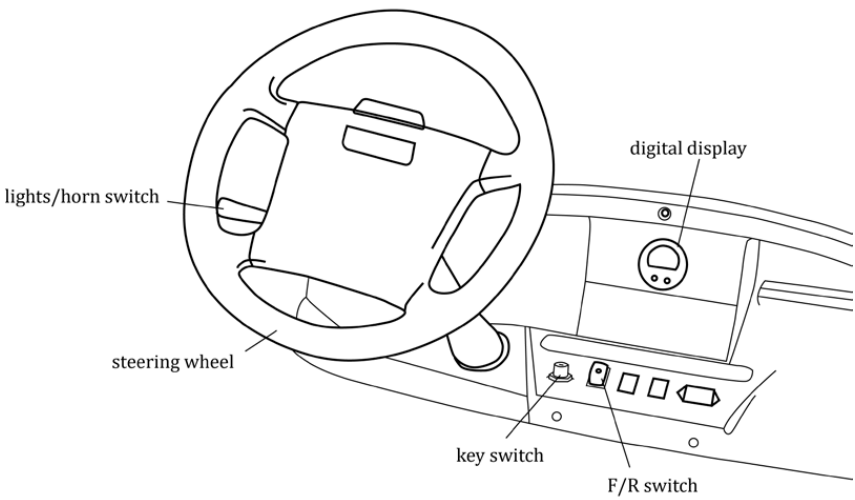



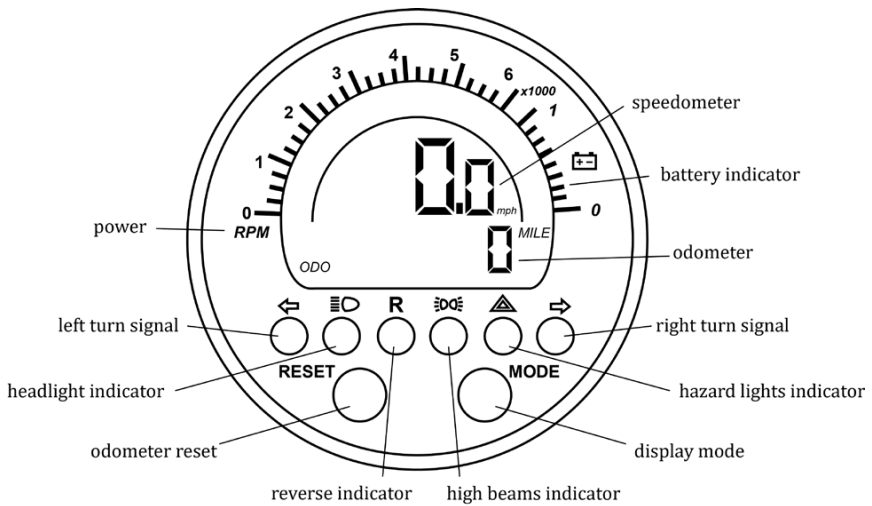

**WARNING:** If lending or reselling the golf car, make sure the driver is familiar with all the controls and rules.

**Reset button:** Resets the trip meter to 0.

**Mode button:** Switch display to trip, runtime, and odometer.

**Main Switch:** The main switch can be found on the instrument desk below the steering wheel.

*OFF:* Electrical circuit is switched off. The key can be removed only in this position.

*ON:* Electrical circuits are switched on. The golf car can be driven.

**Drive Select Switch (F/R switch):** The F/R switch is used to shift the golf car into forward or reverse. In order to avoid occupants' injury and protect cars, move the switch to the desired position after coming to a complete stop.

**Parking Brake:** Press down on the brake pedal to stop the golf car after releasing the accelerator pedal. Your Magellan is equipped with an electromechanical parking brake. It will engage automatically when car is at a complete stop or key switch is in OFF position. Wait until the car has come to a complete stop before leaving the vehicle. Pay special attention if the car is on a steep hill or the road condition is wet or covered with ice or snow; the parking brake may not be able to completely stop the vehicle. The parking brake will automatically release when the accelerator pedal is depressed. If the main switch is in the ON position, depressing the accelerator

may suddenly cause the golf car to move.

The drive select switch is used to shift the golf car into forward or reverse. After coming to a complete stop, move the lever to the desired position.

| Switch Position | Car Movement |
|-----------------|--------------|
| F               | Forward      |
| R               | Reverse      |
| O               | None         |

The back-up buzzer will sound when the drive select switch is turned to reverse. When switched to O position, the car does not move even if the accelerator pedal is depressed.

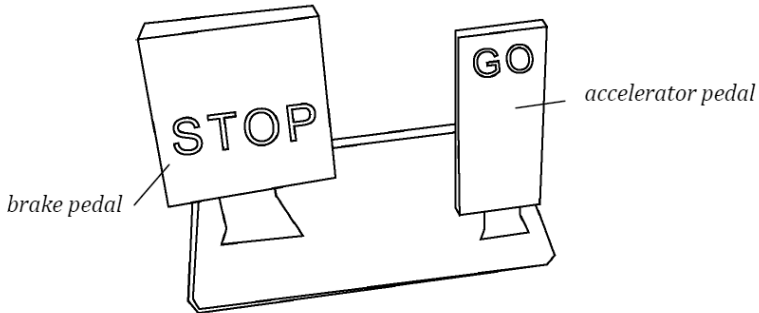

**Accelerator Pedal:** The accelerator pedal can be found on the right side labeled GO. This pedal is different from the accelerator pedal in common car. Turn on the main switch and select the F/R switch to move forward or in reverse and the golf car's speed will accelerate gradually as the accelerator pedal is depressed. Releasing the pedal causes the power to be cut and the motor to stop working gradually.

**Brake Pedal:** The brake pedal is the larger one on the left side labeled STOP. Press down on the brake pedal to stop the golf car.

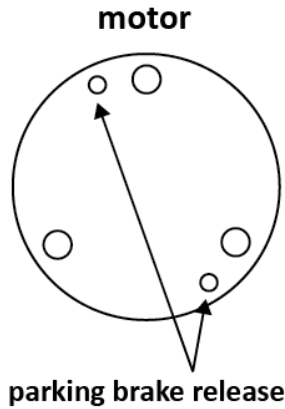

**WARNING:** The parking brake will automatically release when the accelerator pedal or the brake pedal is depressed.

To release the parking brake manually, insert two M5 bolts on the back of the motor as shown. Two M5x45mm bolts and an Allen key are in a plastic bag in the battery compartment.

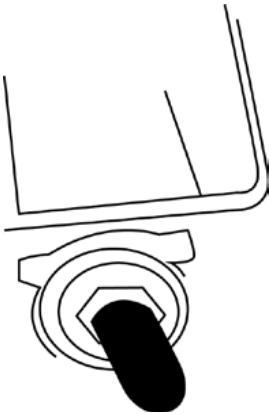

**Tow Switch:** The Tow switch is located in the front of the battery container. The switch can be seen clearly when the seat bottom is being opened by means of pulling the armrest forward. Pulling the switch to TOW (or OFF) will cut the power off and make the car stop.

Before towing the car: When the anti-slide function is active, pull the switch to TOW (or OFF to cut off the power for the protection of the electric integrated circuit).

Before connecting or disconnecting cables: Pull the switch to TOW (or OFF) to cut off the power and avoid a battery explosion. Allow at least a 10 minute interval when changing the switch.

**Body and chassis:** Before each use, visually inspect the golf car body and chassis for damage and/or missing parts.

### Daily Checklist

- Use the checklist as a guide to check the daily running condition and the car.
- Drive select switch (F/R switch): Check to make sure the switch works properly.

- Pedal operation: Check the following pedal controls for proper operation. If a pedal does not work properly, consult a Star EV dealer. Make sure the brake pedal feels firm when pressed and returns to its original position when released. Press down on the brake pedal. The brake pedal should not touch the floor of car. Make sure the parking brake works properly when the electromechanical park brake is engaged. You should not be able to push the vehicle, and the brake should release automatically when the accelerator pedal is pushed.
- Back-up buzzer: Check the buzzer by moving the drive select switch to REV for reverse. The buzzer should sound.
- Steering system: Check the steering system for excessive free play by moving the steering wheel up, down, back, and forth, and turning the steering wheel slightly to the right and left. If you feel excessive free play or hear rattling sounds which may indicate loose steering components, consult a Star EV dealer.
- Sounds: Check for abnormal sounds when running.

### 3: Pre-Operation Check

Every Star EV vehicle has been checked and adjusted thoroughly. Be familiar with controls, indicators, and operations.

Please use the check list as a guide. Pre-operation checks should be made each time you use your golf car. Get in the habit of performing the following checks.

**WARNING:** Be sure the main switch key is removed before performing the pre-operation checks to prevent accidental starting.

#### ***Pre-Operation Checklist***

Before each use check the following:

**Batteries:** Check that the batteries are held securely in place to prevent them from being damaged from vibration or jarring. Also check that no battery caps are missing to prevent battery acid from spilling from the batteries. Check the battery terminals for corrosion.

**Tire condition:** Check the tire air pressure before operating the golf car. Check the tire surface for damage, cracks or embedded objects. When tire tread wears down to 0.04" (1 mm), replace the tire.

## Operation

1. Learn the controls of the vehicle.
2. Make sure every occupant remains seated.
3. Read the warnings on the indicator board.
4. Make sure the steering wheel works well.
5. Turn the main switch to ON. Check that your path is clear.
6. Turn the drive select switch to FWD for forward, or REV for reverse.
7. Slowly depress the accelerator pedal, and the locked parking brake will automatically release. The golf car will start to move. The speed increases gradually as the accelerator pedal is depressed.

**WARNING:** Control the speed when descending a slope. The brake can control the speed when descending a slope.

**CAUTION:** Pressing the F/R switch to the O position cuts off the power and the car stops.

### Stopping

1. To stop the golf car, gradually press down on the brake pedal.
2. When the car has come to a stop, the parking brake will automatically engage. You should hear a click sound.
3. Turn the main switch to OFF. Switch the F/R switch to the O position, and take out the key when not in use.

## 4: Storage

1. Perform the following preparations when storing your golf car for extended periods of time:
2. Turn main switch key to OFF position, remove key, and store key in a safe place.
3. Verify the tire pressure is set to 35 psi.
4. Clean the exterior of the golf car.
5. Cover the golf car with a breathable cover and store it in a dry, well-ventilated area.
6. Have the batteries recharged every 60-90 days to keep them fully charged. The batteries must be kept fully charged to avoid damage.
7. Have the car lubricated every 6 months.
8. Clean the top of the batteries with a solution of baking soda and water, as necessary, to remove corrosion.
9. Trap the wheels to avoid the car moving.

# 5: Maintenance

## **Periodic Maintenance Chart**

Regular maintenance is required for the best performance and safe operation of your golf car. Be sure the main switch is off and the parking brake is engaged when you perform maintenance unless otherwise specified. If the owner is not familiar with machine servicing, this work should be done by a Star EV dealer or other qualified mechanics.

| Item  | Daily/<br>Pre-op | Monthly | Six<br>Months | Yearly | Four<br>Years |
|---|------------------|---------|---------------|--------|---------------|
| Charge  | S                | S       | S             | S      | S             |
| Clean battery tops, check for tightness of screws and terminals   | S                | S       | S             | S      | S             |
| Check brake pedal free-play and adjust if necessary               | C                | CA      | CA            | CA     | CA            |
| Check steering operation  | C                | C       | C             | C      | C             |
| Check tire pressure, tread depth, and tire surface for damage     | C                | CA      | CA            | CA     | CA            |
| Check body and chassis for damage                                 | C                | C       | C             | C      | C             |
| Check tightness of all bolts, nuts, screws, and rivets            | C                | C       | C             | C      | C             |
| Check reverse buzzer  | C                | C       | C             | C      | C             |
| Check electrolyte level   |                  | C       | C             | C      | C             |
| Check for loose or broken connections                             |                  | C       | C             | C      | C             |
| Clean and lube pedal control area                                 |                  | CL      | CL            | CL     | CL            |
| Check all wire insulation for cracks and/or worn spots            |                  |         | C             | C      | C             |
| Check shock absorbers for oil leaks and damaged springs           |                  |         | C             | C      | C             |
| Perform a discharge test  |                  |         |               | S      | S             |
| Apply terminal protectant   |                  |         |               | S      | S             |
| Check rear axle bearing play for roughness or free play           |                  |         |               | C      | C             |
| Check steering knuckle bushing free play / Adjust wheel alignment |                  |         |               | CA     | CA            |
| Check wheel nut tightness, front wheel bearing play               |                  |         |               | C      | C             |

C: Check  
CA: Check and adjust  
R: Replace

S: Service  
CL: Clean and lubricate  
L: Lubricate

|  |  |  |    |    |
|--|--|--|----|----|
| Check transaxle oil level and inspect for leakage        |  |  | C  | C  |
| Check pedal stop operation and adjust if necessary       |  |  | CA | CA |
| Replace transaxle oil                                    |  |  |    | R  |
| Inspect internal wet brake and replace pads if necessary |  |  |    | CA |

## Battery Care

**WARNING:** Battery electrolyte is poisonous, dangerous, and can cause severe burns. It contains sulfuric acid. Avoid contact with skin, eyes, or clothing.

### Antidotes:

- *External:* Flush with water.
- *Internal:* Call a physician immediately. Drink large quantities of water.
- *Eyes:* Flush with water for 15 minutes and get prompt medical attention.

Batteries produce explosive gases. Keep sparks, flames, and cigarettes away from battery. Ventilate when charging or using in an enclosed space. Always shield eyes when working near batteries.

**WARNING:** Keep out of reach of children.

Eight 6-volt deep cycle batteries provide power for your electric golf car and must be properly maintained and recharged for maximum performance and service life.

### To maintain your batteries:

1. Clean the tops of the batteries with a solution of baking soda and water, as necessary, to remove corrosion. **CAUTION:** Do not allow cleaning solution to enter battery cells.
2. Check the fluid level before and after charging. *Before charging:* Only add distilled water if fluid is below the top of the plates, and then add just enough to cover plates. *After charging:* Add distilled water carefully until the water level is  $\frac{1}{4}$  to  $\frac{1}{2}$  inches up to the plate or at the  $\frac{1}{4}$  and  $\frac{3}{8}$  position in the level indicator. Adding properly distilled water can help to prevent the water from boiling after charging. **CAUTION:** Normal tap water contains minerals which are harmful to a battery; therefore, refill only with distilled water.
3. Using a hydrometer, check the specific gravity of the battery fluid in each cell against the readings on the chart below. Consult a Star EV dealer if any low readings are found, or if readings vary more than one point between cells.

min. level of electrolyte

vent cap

max. level of electrolyte

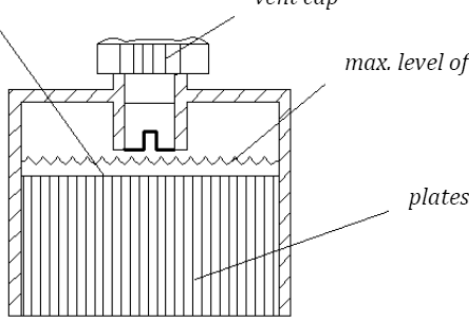

| Temperature |      | Satisfactory Uncorrected Hydrometer Reading |
|-------------|------|---|
| °F          | °C   |   |
| 120         | 48.9 | 1.244                                       |
| 110         | 43.3 | 1.248                                       |
| 100         | 37.8 | 1.252                                       |
| 90          | 32.2 | 1.256                                       |
| 80          | 26.7 | 1.260                                       |
| 70          | 21.1 | 1.264                                       |
| 60          | 15.6 | 1.268                                       |
| 50          | 10.0 | 1.272                                       |
| 40          | 4.4  | 1.276                                       |
| 30          | -1.1 | 1.280                                       |

## Battery Charging

**WARNING:** Read and understand the owner’s manual provided with your golf car’s battery charger before charging batteries.

**WARNING:** Explosive hydrogen gas is produced while batteries are being charged. Only charge batteries in well ventilated areas (a minimum of five air changes per hour is recommended).

To charge the batteries in your golf car, follow the instructions contained in your battery charger’s owner’s manual. The following is a summary of the charging steps.

**WARNING:** Do not attempt to recharge your golf car’s batteries without thoroughly reading and understanding the owner’s manual provided with your charger.



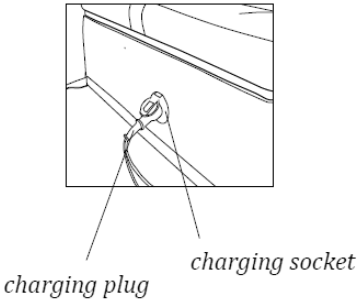

1. Turn main switch key to “OFF” position.
2. With the charger properly connected and grounded (see charger’s owner’s manual), insert the DC output plug into the golf car receptacle. Do not connect the AC with the golf car directly. **CAUTION:** Use only battery chargers that are rated for use with 48-volt Star EV Golf Cars. Thoroughly read and understand the user manual supplied with your 48-volt charger. **WARNING:** Do

not disconnect the DC output cord from the battery receptacle when the charger is on or an arc could occur that may cause an explosion.

3. The charger will turn off automatically when the batteries reach full charge.
4. After the charger has turned off, disconnect the DC output plug from the golf car receptacle by grasping the plug body and pulling the plug straight out of the receptacle.

## Battery Installation

**WARNING:** When working with batteries, do not put wrenches or other metal objects across the battery terminals. This can cause explosion of the battery. Install the battery tie down plates and torque to as shown.

**WARNING:** When installing batteries, carefully place battery cables and tie-downs making sure that cables do not lay across vent caps. Always remove the negative (-) cable to the motor controller first, and install it last.

**CAUTION:** Do not over-tighten the battery tie-down nuts. Excessive force will damage the battery casing.

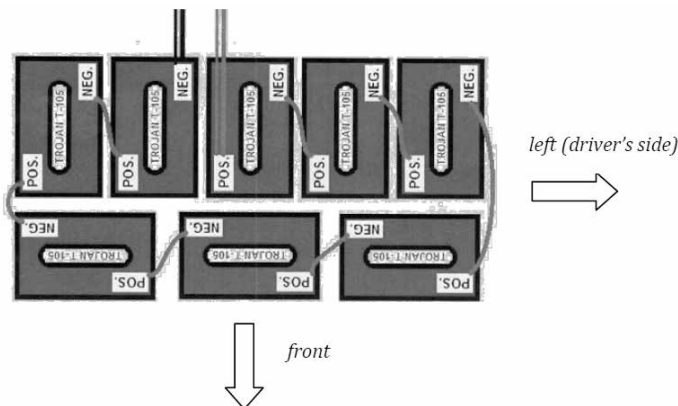

# 6: Electrical Diagrams

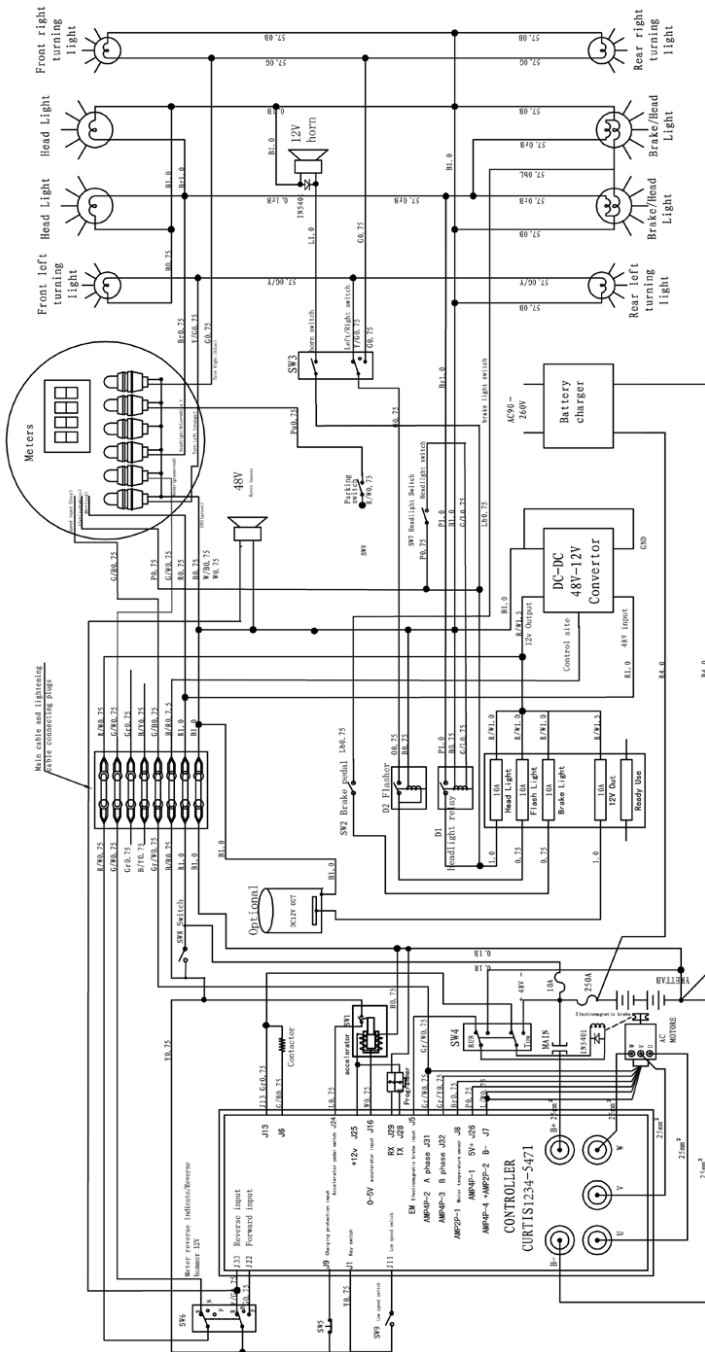

|     |                  |
|-----|------------------|
| SW7 | Headlight switch |
| SW8 | key switch       |
| SW9 | Low speed switch |
|     |                  |
|     |                  |
|     |                  |

|     |   |
|-----|---|
| SW1 | Accelerator output switch                             |
| SW2 | brake pedal switch                                    |
| SW3 | Horn, turn left, turn right switch                    |
| SW4 | Brake EM release switch, double-pole double-throw     |
| SW5 | Charging protection switch often closed, changing off |
| SW6 | Forward/reverse switch double-pole double-throw       |

|    |                     |
|----|---------------------|
| D1 | Headlight relay 12V |
| D2 | Flasher 12V         |
|    |                     |
|    |                     |
|    |                     |

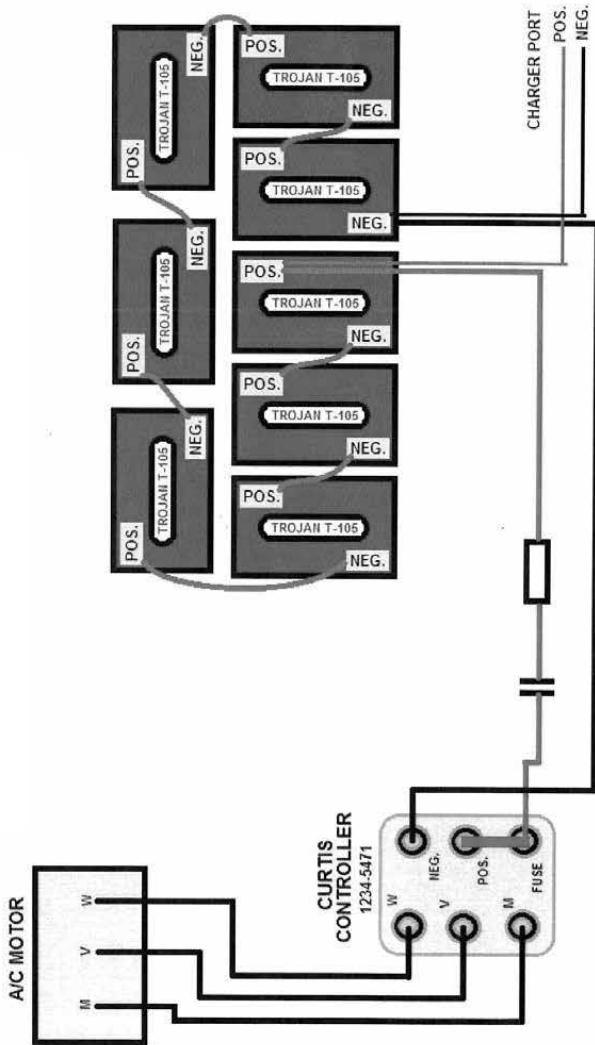

This manual tries to be as sound and elaborate as possible in literal and figurative description as well as technical description on the basis of existing data. At the same time, JH Global reserves the right to alter the content of this manual and this manual is subject to change without prior notice; in addition, JH Global has the final say on the interpretation of this manual.

All rights reserved.



***ELECTRIC VEHICLES***

STAR EV, a brand of JH Global Services, Inc.  
378 Neely Ferry Road | Simpsonville, SC 29680  
[www.starev.com](http://www.starev.com)